



LAMP 5G R16

A brighter approach to 5G connectivity

Not every location has a perfect tower to point at. LAMP 5G R16 uses **omnidirectional antennas and built-in eSIM** to keep you connected to the best available network, making it ideal for urban deployments, backup connectivity, ports, industrial sites, and other demanding environments.



WEATHERPROOF



GNSS



EN 60945
maritime
certified



A modern
5G SA/NSA
modem



Cutting-edge
omnidirectional
antennas



eSIM &
MikroTik
Connectivity



Gigabit
Ethernet +
PoE-in

Not every location has a clear line to a single base station. In cities, ports, industrial sites, and busy transport hubs, there may be several towers within reach – and network conditions can change throughout the day.

LAMP 5G R16 takes a different approach. Instead of locking onto a single direction, its omnidirectional antenna system can connect to the best available network around it, helping maintain reliable service even when conditions change. A tower goes offline? Network conditions change? A better signal becomes available? LAMP 5G R16 can adapt without requiring antenna realignment.



Gigabit Ethernet
with PoE-in

eSIM & MikroTik Connectivity – get online faster and easier than ever!

Deploy devices without handling physical SIM cards. LAMP 5G R16 features a built-in eSIM, allowing operators to **activate data plans remotely and bring new installations online in minutes**. It is fully compatible with MikroTik Connectivity – our simple pre-activated data service that helps you get connected quickly, whether you're deploying a single device or managing a large network.

Need even more flexibility? LAMP 5G R16 also supports **third-party eSIM providers** and **multiple eSIM profiles**. Store different operator plans on a single device and switch between them as your connectivity requirements change. Whether you're managing backup connections, roaming deployments, or multi-operator networks, LAMP gives you more options without needing to swap physical SIM cards.

Built for the outdoors... and even the sea!

Rain, dust, heat, cold, or salty sea air – LAMP 5G R16 is ready for it. The **IP67-rated** enclosure, **EN 60945 maritime certification**, and included stainless-steel mounting bracket make it a reliable choice for demanding outdoor and marine deployments.

Whether deployed at ports, marinas, coastal infrastructure, or aboard vessels, the device is designed to meet the environmental and electromagnetic requirements expected in marine communication environments. Built-in GNSS support provides access to GPS, Galileo, BeiDou, and QZSS satellite systems. This enables accurate positioning information for fleet management, asset tracking, remote infrastructure, and location-aware* applications.



LAMP 5G R16: why settle for one tower when they all could be yours? That's the brighter approach to 5G connectivity.

*GNSS functionality is intended for positioning, tracking, and non-critical location-aware applications. This device is not designed or certified for navigation, route guidance, or safety-critical marine navigation.

• Specifications

Product code	LAMPGM&RG520F-EU
CPU	Dual-core 88F3720 800 MHz
CPU architecture	ARM 64-bit
RAM	512 MB DDR3L
Storage	32 MB Flash
Number of 1G Ethernet ports	1
SIM slots	1 microSIM, eSIM
GNSS standard	GPS, Glonass, Galileo, BeiDou, QZSS
GNSS interface model	RG520F-EU
LTE modem	R11mL-RG520F-EU
TAC	86945405
5G SA Category	DL: 4.2 Gbps; UL: 900 Mbps
MIMO DL	4x4
MIMO UL	2x2
5G SA FDD bands	1 (2100MHz) / 3 (1800MHz) / 5 (850MHz) / 7 (2600MHz) / 8 (900 MHz) / 20 (800 MHz) / 28 (700 MHz)
5G SA TDD bands	38 (2600MHz) / 40 (2300MHz) / 41 (2500MHz) / 75 (1500 MHz) / 76 (1500 MHz) / 77 (3700 MHz) / 78 (3500 MHz)
5G NSA Category	DL: 5.0 Gbps; UL: 650 Mbps
5G NSA FDD bands	1 (2100MHz) / 3 (1800MHz) / 5 (850MHz) / 7 (2600MHz) / 8 (900 MHz) / 20 (800 MHz) / 28 (700 MHz)
5G NSA TDD bands	38 (2600MHz) / 40 (2300MHz) / 41 (2500MHz) / 75 (1500 MHz) / 76 (1500 MHz) / 77 (3700 MHz) / 78 (3500 MHz)
LTE Category	20 (2.0 Gbps Downlink, 200 Mbps Uplink)
LTE FDD bands	1 (2100MHz) / 3 (1800MHz) / 5 (850MHz) / 7 (2600MHz) / 8 (900 MHz) / 20 (800MHz) / 28 (700MHz) / 32 (1500 MHz)
LTE TDD bands	38 (2600MHz) / 40 (2300MHz) / 41 (2500MHz) / 42 (3500MHz) / 43 (3700MHz)
3G Category	R8 (42.2Mbps Downlink, 5.76Mbps Uplink)
3G bands	1 (2100MHz) / 5 (850MHz) / 8 (900MHz)
Dimensions with mount	276 x 267 x 133 mm
IP rating	IP67
Operating system	RouterOS v7, License level 3
Operating temperature	-40°C to +70°C

• Powering

DC input	PoE-In
Input Voltage	12-56 V
Power adapter nominal voltage	24 V
Power adapter nominal current	0.5 A
PoE-In	802.3af/at
Max power consumption (without attachments)	10 W
Max power consumption	10 W

• Included parts



24 V 0.5 A
power adapter

LAMP
Mount

Gigabit
PoE injector

• Antenna gain

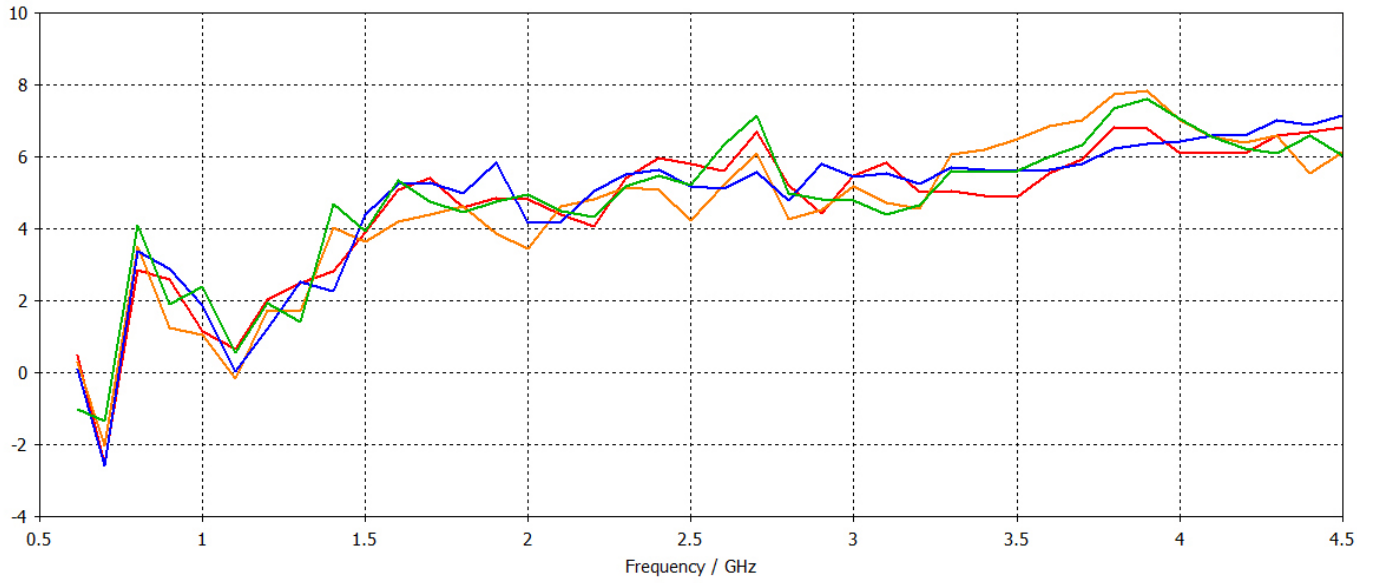

• Mounting

Pole mounting

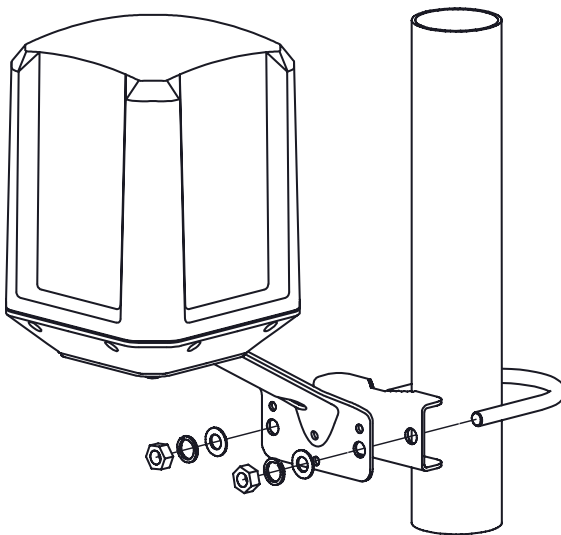

Ø 25-60 mm

Wall mounting

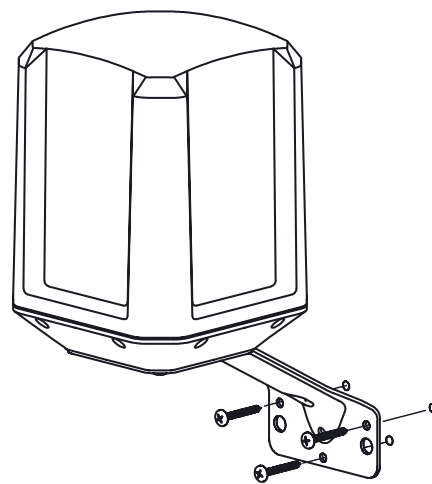

Ø 6 mm predrill
for the dowels